



MaxBlate[®] Microwave Ablation Systems

A New Portable Generation for
XphereTip[®] - ThyTip[®] - SureTip[®] Antennas



Liver



Thyroids



Kidneys



Lungs

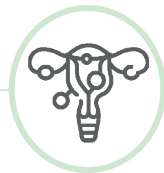

Uterus

About Mermaid Medical Group

Mermaid Medical Group is a privately owned company established in 2007. With our Nordic roots and headquarters in Denmark, we value cooperation, helpfulness, and openness.

We develop, manufacture, and distribute medical devices to hospitals and end users across Europe, the U.S., and Asia.

We primarily work within solutions to diseases in the vascular system as well as other devices used in interventional radiology.

We strive to be the preferred partner for manufacturers as well as hospitals and healthcare professionals so that together we can help even more patients.

All product names, logos, and brands mentioned in this catalogue are property of their respective owners.

Use of these names, logos, and brands does not imply endorsement or affiliation. Trademarks are used solely for the purpose of identifying products and services.



30 years with over
300.000 successful cases



Features:

- Powered by proprietary MaxCore™ inside with ACLC technology and PID algorithm to provide precise and stable MW output.
- IEC 60601-1 compliant for enhanced electrical safety.
- Portable and compact design for convenient transportation, installation, operation and service maintenance.
- Interactive and sensitive touch screen with adjustable power & time setting.
- Cooling and real-time temperature monitoring as well as other incorporated multi-safety monitoring control.
- Continuous and pulsed modes are available for different clinical options.

Precise - Efficient - Stable

Spherical - Less invasive

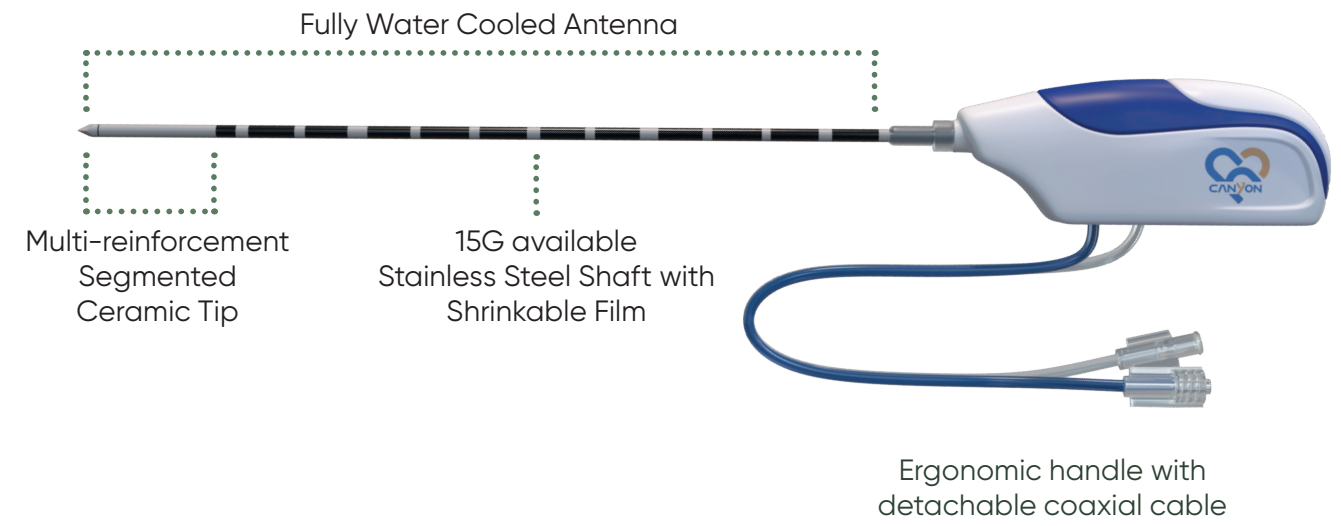
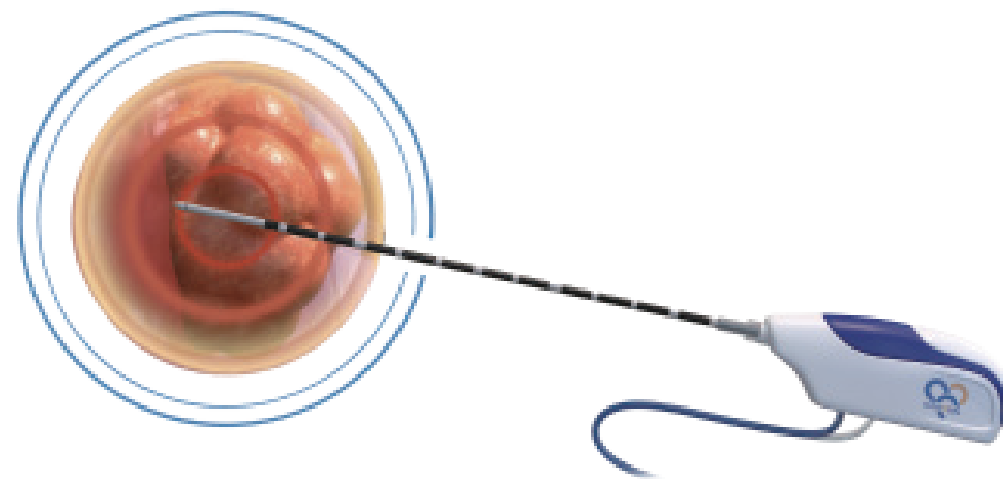

Trocar tip with reinforced ceramic window allows for less friction and less mechanical weakness

Triangular Design

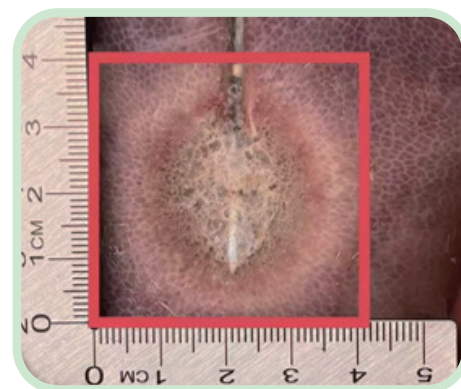
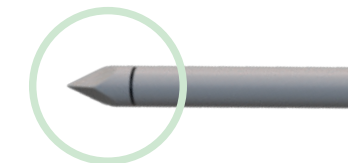

EX-Vivo testing

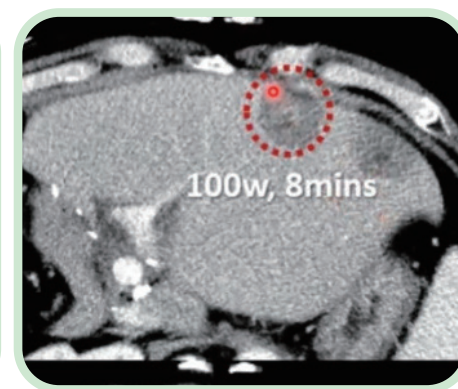

¹In-Vivo Results

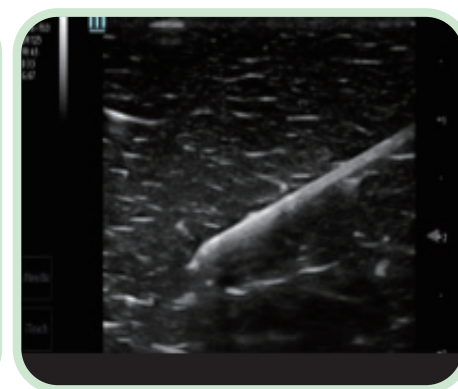

Echogenicity

Features:

- Patented radiation field control technology as well as full-antenna water cooling technology brings a spherical ablation zone.
- Sharp and multi-reinforcement ceramic tip, as well as high-performance stainless-steel shaft, bring an excellent benefit of stiffness and strength in puncture and operation.
- Comparably less invasive 15G in terms of the diameter of the antennas.
- Excellent echogenicity and tip visibility for accurate guidance to the target area under ultrasound.
- Special antenna shaft surface treatment enables smooth puncture movement, and effectively avoids tissue adhesion.
- Ergonomic handle with detachable cable improves operational convenience and maneuverability.

¹ 71/M, Cholangiocarcinoma s/p right hepatectomy /w recurrence, case done by MaxBlate® Microwave Ablation Generator, XphereTip® 15G antenna.

Efficient & Controllable



Ergonomic handle with detachable coaxial cable

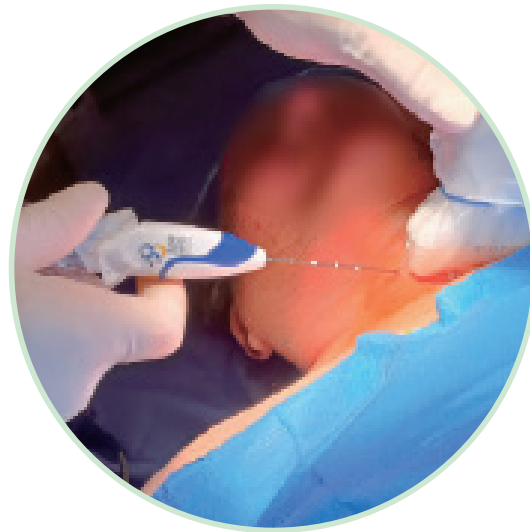

Features:

- 3mm active tip optimized for the ablation of superficial and small thyroid with a uniform and well controlled result.
- Excellent echogenicity and tip visibility for accurate guidance to the target area under ultrasound.
- Internally water cooled and operate by moving shot to avoid tissue overheating.
- As thin as 18G, less invasive.

Sharp needle tip and thin diameter makes the placement easier due to less friction

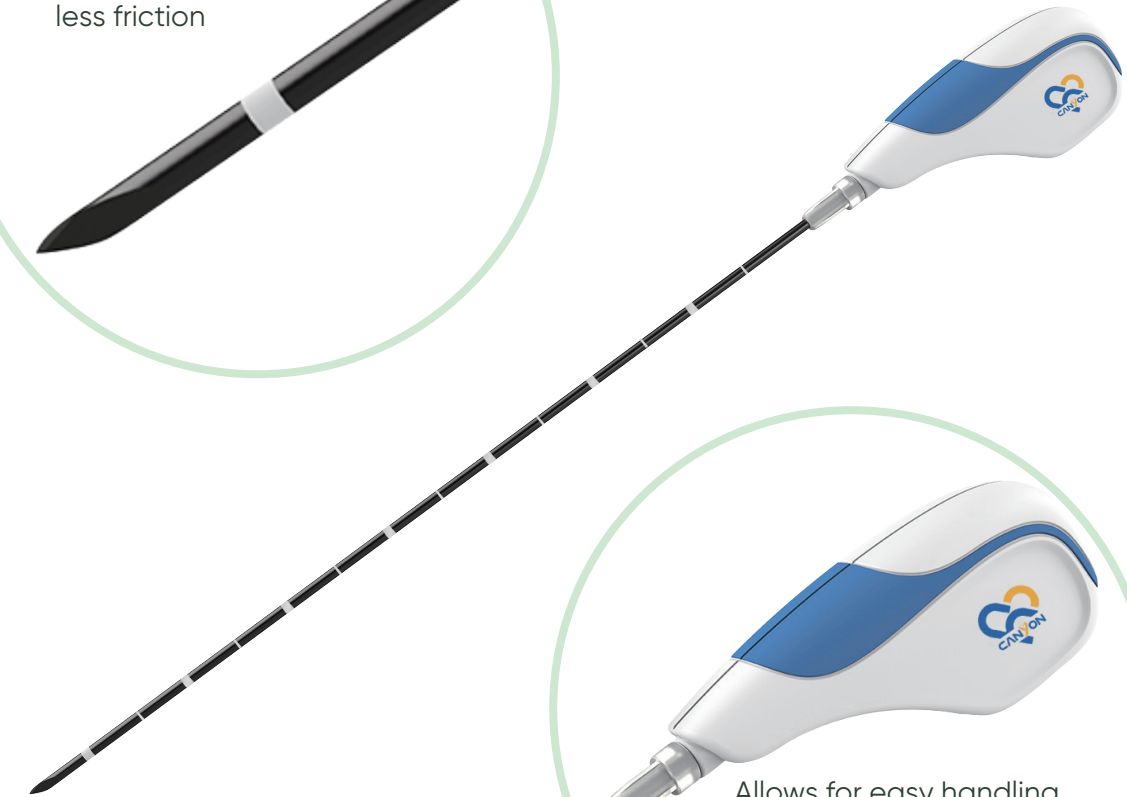

Allows for easy handling of antenna and flexibility regardless of image modality



Features:

- High performance material to ensure better connection and strength.
- Unique shaft coating material to avoid tissue adhesion.
- Sharp needle tip and thin diameter, making it less invasive.
- Internally water cooled antenna with intelligent temperature control.
- Signal enhancement design for better visibility under CT or ultrasound guidance.
- High efficiency detachable cable, unique enhanced connection with the antenna.

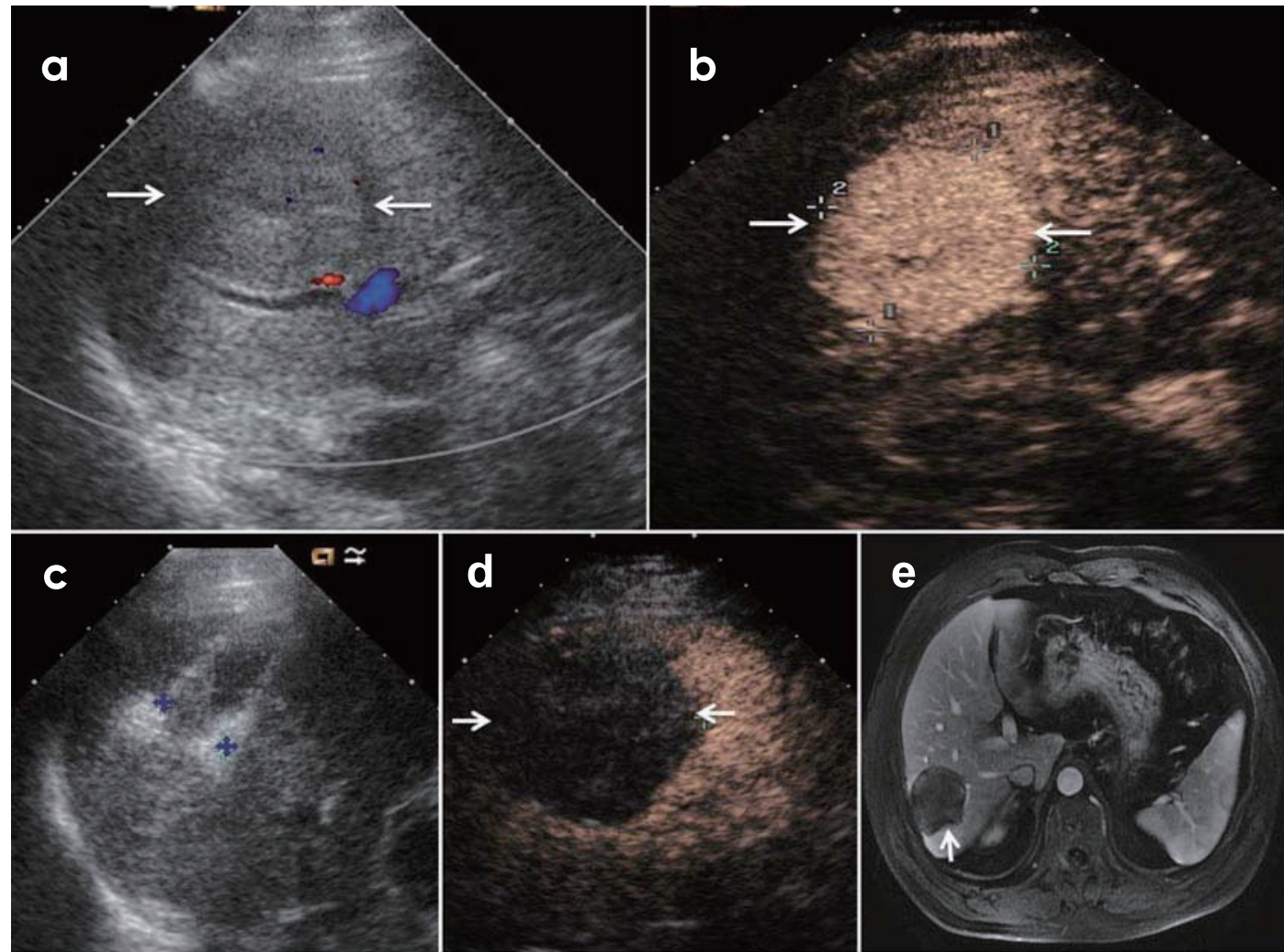

Benefits of Microwave Ablation

Microwave ablation can generate larger ablation zones in shorter time with less sensibility to heat sink effect. Moreover, MWA radiates all biological issues, such as bone, lung, charred or desiccated tissues. Additionally, multiple antennas can be placed to treat simultaneously for large tumors or multifocal lesion.

With MaxBlate[®] New Generation Microwave Ablation System, the achieved ablation zone can be uniform, homogeneous, and predictable. In addition, a choice of antennas and customized settings provides the user with unique opportunities for clinical diversity during treatment.

- (a)** Preablation conventional ultrasound (US) scan shows a hypoechoic lesion with blood supply (arrows).
- (b)** Contrast-enhanced US before MWA shows tumor enhancement in arterial phase with the size of 5.5 x 4.7 cm. (arrows).
- (c)** Conventional US shows two microwave antennas (mark) placed in the tumor.
- (d)** Contrast-enhanced US shows no enhancement of the ablation zone at 12 months after treatment (arrows)
- (e)** MRI scan obtained 21 months after ablation shows hypoattenuating ablation zone (arrow) without enhancement.

Above statements refers to the following publication

P. Liang et al. (eds.), Microwave Ablation Treatment of Solid Tomors, DOI 10.1007/978-94-017-9315-5_4, © Springer Science+Business Media Dordrecht 2015,

Custom made trolley and foot pedel for use with MaxBlate[®] MWA Generators

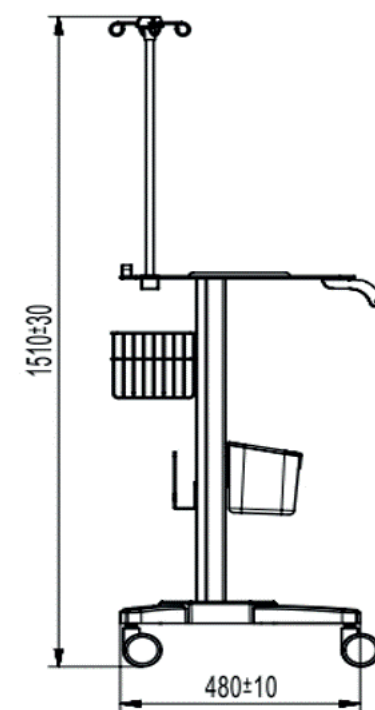
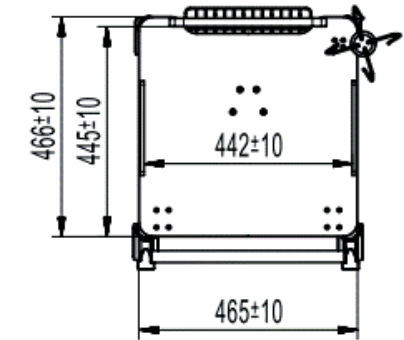
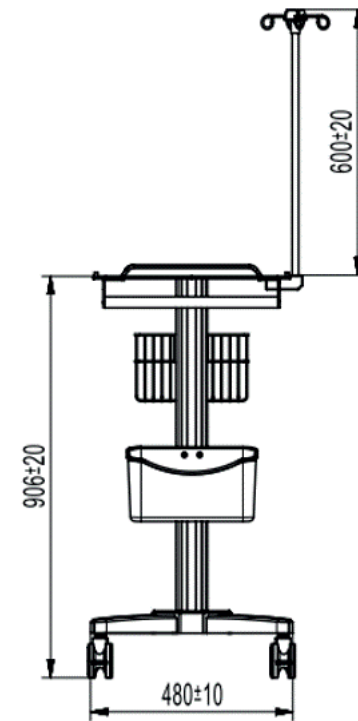

Ordering and Specifications

MaxBlate® Pro

Ref	KY-2100A
Frequency	2450 Mhz
Display	7 inch Touchscreen
Energy Output	5-150W
Time Setting	1-30 Minutes
Working Power	100V-240V 50-60 Hz
Weight	12 kg
Size	46x40x18cm

MaxBlate®

Ref	KY-2000A
Frequency	2450 Mhz
Display	7 inch Touchscreen
Energy Output	5-100W
Time Setting	1-30 Minutes
Working Power	100V-240V 50-60 Hz
Weight	12 kg
Size	46x40x18cm



Custom made trolley for use with MaxBlate® MWA Generators

Ref.	Specifications
KY-NPTC-1-01	Trolley for use with MaxBlate® Generators

Foot pedal for use with MaxBlate® MWA Generators

Ref.	Specifications
KY-C	Foot pedal for use with MaxBlate® generators

XphereTip® Antennas

Ref	Diameter	Active Tip	Total Length
KY-2450B-QT4	15G	25 MM	100 MM
KY-2450B-QT5	15G	25 MM	150 MM
KY-2450B-QT6	15G	25 MM	200 MM
KY-2450B-QT7	15G	25 MM	250 MM
KY-2450B-QT8	15G	25 MM	300 MM



ThyTip® Antennas

Ref	Diameter	Active Tip	Total Length
KY-2450B-5	16G	3 MM	100 MM
KY-2450B-13	16G	3 MM	70 MM
KY-2450B-4	18G	3 MM	70 MM
KY-2450B-14	19G	3 MM	70 MM



SureTip® Antennas

Ref	Diameter	Active Tip	Total Length
KY-2450B-T4	15G	11 MM	100 MM
KY-2450B-T6	15G	11 MM	150 MM
KY-2450B-T7	15G	11 MM	200 MM
KY-2450B-T10	15G	11 MM	250 MM
KY-2450B-T14	15G	11 MM	300 MM
KY-2450B-T1	16G	11 MM	100 MM
KY-2450B-T2	16G	11 MM	150 MM
KY-2450B-T3	16G	11 MM	200 MM
KY-2BBC-24D	16G	11 MM	300 MM
KY-2450B-T11	18G	11 MM	100 MM
KY-2450B-T5	18G	11 MM	150 MM
KY-2450B-T13	18G	11 MM	200 MM



All antennas come with a compatible coaxial cable



mermaid medical[®]

Mermaid Medical, Inc.

7340 South Alton Way, Suite 11-H
Centennial, CO, 80112, USA
Customercare@mermaidmedical.com
Phone: 720-420-9999

MM 01-8000-01 USA Rev. 01.